

HABONIM

Double Block & Bleed (DBB) Full Port Flanged valve Installation, Operating & Maintenance

Series included:

73X, 74X, AF73P, AF74P

Sizes Included:

3" - 8" (DN80 - DN200)

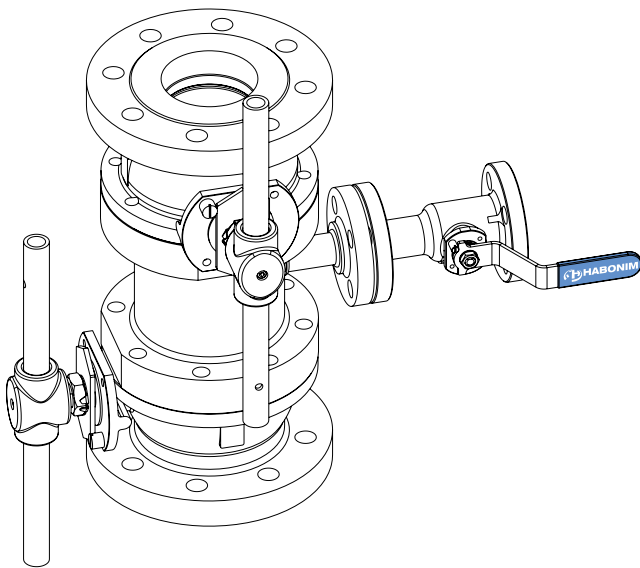

1. GENERAL

This Installation, Operating & Maintenance manual presents the instructions required for safe use of Habonim full port flanged DBB valves. Before using any of these series valves, read the entire IOM carefully and make sure you understand everything. Where in doubt, please consult with Habonim engineering team.

WARNINGS & SAFETY INSTRUCTIONS

Habonim cannot anticipate all of the situations a user may encounter while installing and using Habonim valves. The user **MUST** know and follow all applicable industry specifications on the safe installation and use of these valves. Misapplication of the product may result in injuries or property damage. Refer to Habonim product catalogues, product brochures and installation, operating and maintenance manuals for additional product safety information or contact Habonim.

1. Keep hands and objects away from the valve ports at all times. Actuated valves could be accidentally operated, resulting in serious injury or valve damage.
2. Before removing a valve from the line, always make sure the line has been depressurized and drained. Cycle the valve a few times to relieve any pressure that could be trapped in the body cavity.
3. Utmost caution must be taken when handling a valve that has toxic, corrosive, flammable or a contaminant nature media flowing through its pipeline. The following safety precautions are recommended when dismantling valves with hazardous media:
 - a. Wear eye shield, protective headgear, clothing, gloves and footwear.
 - b. Have available running water.
 - c. Have a suitable fire extinguisher when media is flammable.
5. Do not try to operate a valve that exhibits any sign of leakage. Isolate the valve and either repair or replace it.
6. Do not use or substitute non Habonim components or parts in Habonim valves and assemblies.



Kfar Hanassi, Upper Galilee 12305 Israel
Tel: 972-4-6914911
Fax: 972-4-6914902
E-Mail: habonim@habonim.co.il
www.habonim.com

DEDICATED TO INNOVATION

2. SIL

Under normal operating conditions the Habonim valve should be inspected for proper functioning and signs of deterioration every 50,000 cycles or 6 months (whichever comes first). Under severe operating conditions inspection should be more frequently; detected defects should be repaired promptly.

Severe operating conditions can be defined as:

- Application temperature less than -20 deg C
- Application temperature higher than +230 deg C
- Flow velocity higher than 5 m/sec for liquids, and 200 m/sec for gaseous
- Acidic media PH < 5 or alkaline media PH > 9

Habonim recommend a proof test interval of 12 months; in case of Fail to Open ESD system a partial stroke is acceptable to confirm that the installation is functioning properly.

For ESD systems with a Fail-To-Close demand, it is necessary to plan a system shut-down; de-energize the system and inspect the valve turning to its fully closed position.

It is essential to log-in the following parameters on site QA records as a proof for preserving SIL capabilities: date, hour, name and signature of the responsible engineer, air pressure on site, time to close the valve, time to open the valve.

Habonim recommend valve full maintenance operation every 500,000 cycles or 4 years, whichever comes first (refer to para. 7 in this IOM for maintenance instructions). The combined corrosion and erosion allowance for the valve body wall thickness is 1 mm. When this allowance has been eroded or corroded, mechanically removed or otherwise, the valve should no longer be used. Inspect the valve wall thickness every time the valve is maintained. Refer to Habonim Corrosion Data Chart T-614 to determine the corrosion rate for your application.

The estimated mean time to repair (MTTR) a valve, i.e. time net (line draining or cooling down time excluded from the valve MTTR) of replacing old valve with a new one is 60 minutes. Maintenance team must read and understand the Habonim product IOM before starting the operation. In case of a doubt please consult the Habonim engineering team.

When a valve has been repaired or any maintenance was performed, check the valve for proper function (proof testing). Any failures affecting functional safety should be reported to the Habonim factory. Client should consult the Habonim factory in order to obtain the product assessment, FMEDA report, and other associated statistical data to satisfy SIL level.

3. LIMITATIONS

The correct selection of materials of construction, seats and seals, internal valve components and pressure/temperature ratings determines the safe use of the valves and the particular performance requirements for the application. This information can be found on the nameplate welded to the valve body.

It is not possible to cover all installation and maintenance instructions for service of the valves, as the extent of applications that these valves can be used in, is large. It is the user's responsibility to use the valves as recommended and in accordance with the pressure

and temperature limits as stated on this tag. Where in doubt, please consult with Habonim.

Unstable fluids or gases are prohibited for use in Habonim valves.

CAUTION:

The valves should be used in a well designed, adequately protected system to **ensure that external and internal pressure and temperature limits do not exceed the valve limits.**

The valve rating is defined as the lower rating of the seat, end connection and valve body.

Valve surface temperature may become extremely hot or cold due to operating conditions. Prevent any type of direct contact with the valve that may cause harm or injury. Avoid direct contact with the valve by wearing protective gloves.

The valves should be used in a well designed, adequately supported piping system such that it will not be subjected to undue forces, stresses or shock loads during service.

The valves are not designed to operate during or after earthquakes or under fatigue conditions. It is the responsibility of the owner to determine if fatigue conditions exist.

Do not allow dust layers to build up on the equipment.

The process fluid temperature shall not exceed the ignition temperature of the dust.

4. STORAGE

Prior to storage, inspect the valve for shipping damage. Keep all protective packaging, flange covers and end caps attached to the valves during storage. It is recommended to keep the valves in a clean and dry environment until ready for use.

Carbon Steel valves have a "black oxide" and oil dipped finish. This nontoxic process is performed to retard rusting during storage. It is not a substitute for paint or other means of protective coating to be applied to the valve once installed.

Stainless steel valves have their natural finish and do not require additional protection once installed.

5. OPERATING INSTRUCTIONS

Habonim Valves provide tight shut off when used under normal conditions and in accordance with Habonim's published pressure/temperature chart. If these valves are used in a partially open (throttled) position, seat life may be reduced. Consult with Habonim for the proper seat material selection.

On manual operated valves, the valve operation is done by turning the valve handle 90° clockwise to open (handle is parallel to flow line), and 90° counter clockwise to close (handle is perpendicular to flow line).

The bleed line should be in closed position while flow line is in open position, and open when flow line is in closed position.

Note:

Changing the position of bleed line handle should be done only after change of both flow line handles.

All standard valves are bidirectional and as such, can be installed for flow in either direction. Valves which are unidirectional will have a flow direction arrow welded to the body and separate assembly instructions.

A silicone-based lubricant is applied to assist valve break in. The

lubricant, if unacceptable, may be removed by a solvent wash.

If a shut-off valve is installed for end of line service, it must be ensured that it is closed with a blind end connection and the valve is secured against being opened unintentionally.

WARNING: Never look into the valve bore while the valve is in a flowline. Pressure and fluids could escape from the valve causing harm or injury.

To prevent leakage, malfunctions resulting from internal wear or seal degradation, the user must establish a preventive maintenance and inspection program. This program must include:

- a. Inspection of parts to detect loss of wall thickness which may result in decreased pressure capacity (see **para. 2** for acceptable reduction of wall thickness).
- b. Routine replacement of seals and inspection for proper operation (See **para. 7** for maintenance instructions).

Valve operating torques, as published in the Habonim literature, are the normal expected maximum break-out torques. These torques have been confirmed by laboratory testing of each valve under controlled conditions. Highly viscous or abrasive media, frequency of operation and temperature fluctuations could cause an increase in valve torque.

Replace the wrench or actuator. It is recommended not to rotate the valve to the closed position before flushing the line.

6. INSTALLATION

The installation procedure for DBB ball valves is critical to ensure both long life and satisfying performance. Valves stored on site, awaiting installation, should be kept in their original packing, in dry conditions, where damage will not occur (see para. 4). Before carrying out the installation, it is important to follow the basic procedures described below:

6.1 General

- 6.1.1. Carefully unpack the valve and check valve nameplate for identification of materials (see **Figure 2**).
- 6.1.2. Remove any special packing materials surrounding the valve.
- 6.1.3. Check the valve for any flow direction indication marks. Appropriate care must be taken, to install the valve for proper flow orientation.
- 6.1.4. Inspect the valve interior through the end ports to determine it is clean and free from foreign matter according to ASME G93-03E1.
- 6.1.5. Cycle the valve (all handles for flow direction and bleed line), and inspect any functionally significant features.
- 6.1.6. Read all the literature and note any special warning tags or plates attached to the valve.
- 6.1.7. Before installation check to insure that the flow direction balls are in the fully open position in order to prevent possible damage to the balls and seats. The valve performance depends on its original conditions.
- 6.1.8. At any stage do not leave the valve in the partially open position on either of the lines.
- 6.1.9. Valves with flanged ends should be treated as a single unit and should not be dismantled when installing to pipeline.
- 6.1.10. Before installing the valves, make sure that the flanges on

the mating pipe are free from excessive grit, dirt or burrs, and that there is no mechanical damage to the flange face.

- 6.1.11. Use appropriate joining sealants material in correct quantities.

7. MAINTENANCE

HABONIM valves have a long and reliable life, and maintenance is seldom required. When maintenance is necessary, valves can be refurbished on site.

To extend valve performance and reduce possible plant problems, the following procedures should be followed:

- 7.1. If leakage around any stem is noticed, check the stem nut torque according to value in **Table 1**. If the leak continues, tighten the gland nut about a 1/8-turn as a routine maintenance procedure. This will compensate for any wear or settling of the gland packing.
- 7.2. **Caution:** Excessive tightening of the stem nut can result in accelerated seal wear and high valve operating torque.
- 7.3. If the valve is removed from the line and disassembled, replacement of all seats and seals is recommended using the appropriate Habonim Repair kit. Examine all metallic sealing surfaces such as ball, stem, and the surfaces on the end connectors that contact the seats for wear, corrosion or damage.
- 7.4. Only Habonim's authorized spare parts should be used. Repair kits from Habonim consist of the following:
 - 6 x seat ring
 - 3 x stem packing
 - 3 x stem thrust seal
 - 3 x body seals
- 7.5. In addition to repair kits, other spare parts are available from Habonim, such as: valve balls, stems, glands, bolts, screws and nuts. Should additional parts be required, it is recommended that the complete valve be replaced.
- 7.6. When ordering repair kits, please provide the valve size and full figure number code and series, engraved on the valve ID tag.

8. DISASSEMBLY

- 8.1. Cycle the valve with the line pressure fully relieved before attempting to remove the valve from the pipeline, to insure pressure has been discharged from the valve cavity.
- 8.2. Rotate the all valve handles to the "open" position (see para. 5 for valve handle position). **Warning:** trying to remove the valve body from the line, while the ball is in closed position, will damage the ball.
- 8.3. With the handles in the "open" position, loosen all 16 body bolts and 4 bleed line bolts.
- 8.4. Remove all body bolts and bleed line bolts, so the valve body center section is not attached to flange ends (see **figure 3**).
- 8.5. Remove and discard the seat rings and body seals. Be careful not to damage the sealing surfaces.
- 8.6. Support the ball to prevent it from falling out of body and turn handle to the "close" position for its removal (see para. 5

for valve handle position). Set the ball aside in a clean and secure area for reuse.

- 8.7. Remove the handle nut, serrated washer, handle, locking clip, stem nut, disk springs and follower. Place all removed components, in a clean and secure area.
- 8.8. Push the stem down into the body cavity and remove it (do not damage the body core). Discard the stem thrust seal, bearing and packing, care taken not to scratch or nick the stem bore area of the body. Clean the stem and stem bore area.
- 8.9. Repeat steps 8.6 to 8.8 for other balls in valve

9. ASSEMBLY

- 9.1. Lubricate the new stem thrust seals, bearings and packing's, with appropriate lubricant (Molykote 33 - thin smear). Place the stem thrust seals on the stem.
- 9.2. Insert the stem in horizontal position into the body center section, with the threaded side first and carefully guide it up through the stem bore.
- 9.3. Holding the stem up, insert the new packing over the stem and into the stem bore. Place the follower and two disk springs onto the stem. The first spring's convex facing down, and the second spring convex facing up.
- 9.4. Thread the stem nut onto the stem. Tighten the stem nut to the torque figures (**Table 1**).
- 9.5. Place the locking clip on the stem nut by adjusting the orientation of the nut (in the clockwise direction).
- 9.6. If required, place the handle, serrated washer and thread the handle nut on the stem. Tighten the handle nut, while holding the handle.
- 9.7. Repeat steps 9.2 to 9.6 for each stem/ball assembly.
- 9.8. Bring each handle to the closed position to insert the ball.
- 9.9. Place each ball in the body center section until the stem tongue is engaged, and turn the handle so the valve is at open position, to prevent the ball from falling out.
- 9.10. Place the new body seals and new seat rings in the body.
- 9.11. Ease back the body assembly between end connectors, taking care not to score faces or damage seals, and reinstall body bolts, bleed line bolts and nuts.
- 9.12. To prevent galling of threads of bolts or nuts, lubricate threads with an anti-galling compound.
- 9.13. Tighten the body bolts and bleed line bolts to the torque figures (**Table 2**), and according to tightening pattern illustrated in **figure 1**.
- 9.14. Leave the valve in the open position for line flushing.

TABLE 1
Stem Nut Tightening Torque

Full Bore	Nut Thread	* PTFE Gland Packing		Graphite Gland Packing	
		Nm	in.lb	Nm	in.lb
3"	1"-14 UNS	60	530	72	637
4"	1"-14 UNS	60	530	72	637
6"	1 ½"-12 UNF	120	1060	145	1280
8"	1 ½"-12 UNF	120	1060	145	1280

* These torque figures are applicable on other stem seal materials such as glass filled PTFE, UHMWPE and TFM.

IMPORTANT:

An excessively tightened stem nut can cause excessive packing wear and increase stem torque.

TABLE 2
Body Bolt Tightening Torque

Full Bore	Bolt Thread	Tightning Torque	
		Nm	in.lb
3"	M12	65	575
4"	M12	65	575
6"	M16	160	1420
8"	M20	300	2655

FIGURE 1
Body Bolt Tightening Pattern

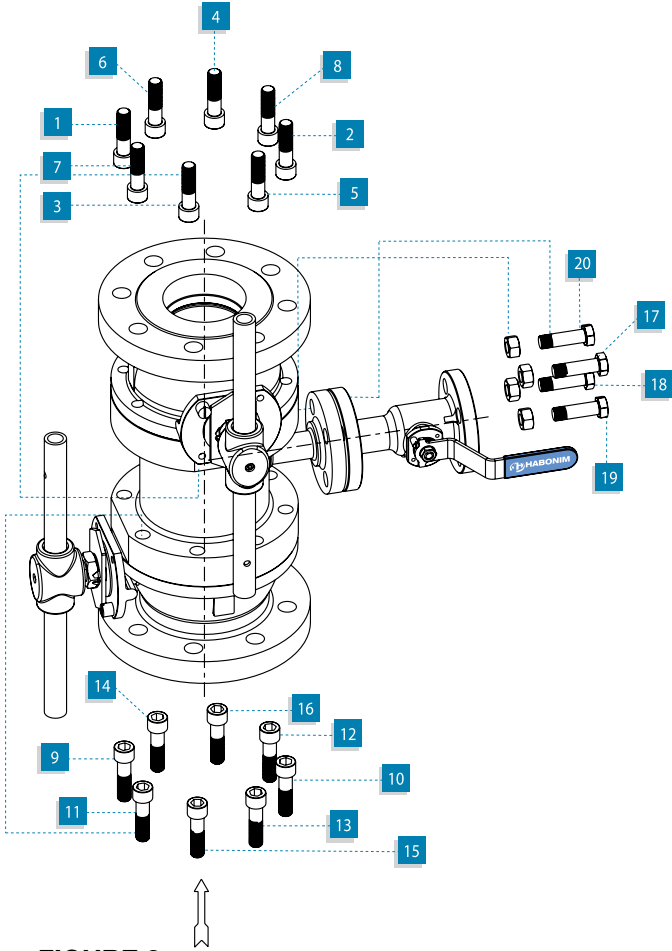

FIGURE 2
Valve Marking and Labeling

All valves marking is on a nameplate which is spot welded to the valve body. Valves for the European market and above 1" carry the CE mark with the information required by the PED.

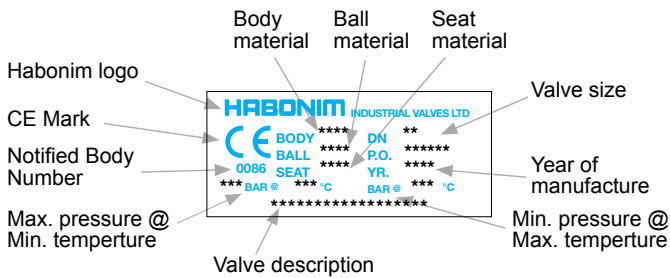
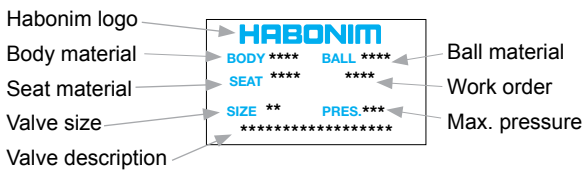
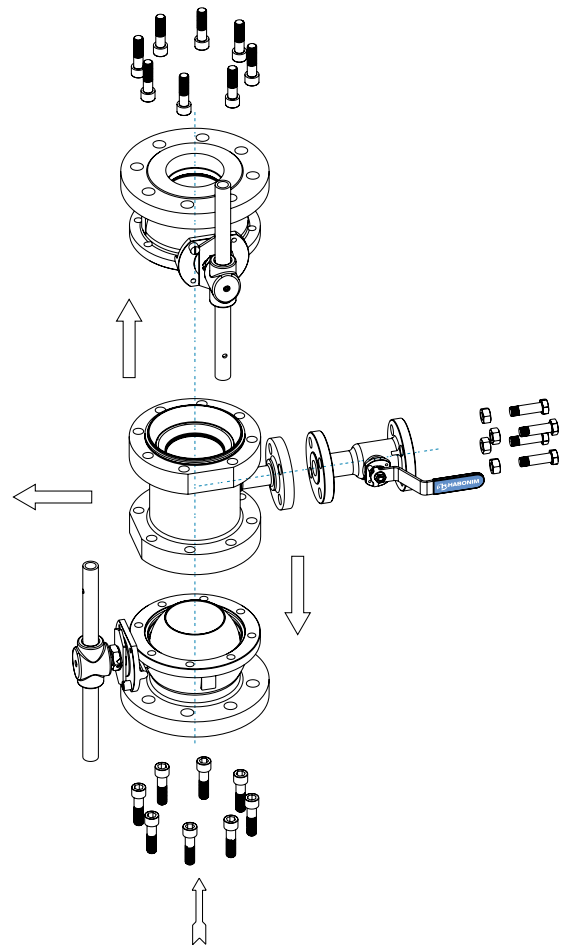

FIGURE 3
Valve slide out direction (disassemble offline)



The DBB ball valves are off-line repairable. Prior to servicing the valve, bring it to the open position making sure to release line pressure and drain all trapped media from the valve cavity. Keep the valve in the open position and remove all but one body bolt, so the valve body can be removed from its installed position and be brought out of the pipe line. In this position it is easy to replace all internal parts and then swing the body back to its original position.

Habonim reserves the right to change design features without prior notice.

HABONIM Full Port Flanged DBB Installation, Operating & Maintenance

Item	Description	Material Specification	Qty.	
			Flow Line	Bleed
1	Body	S.St 316L , C.St A105, C.St A350 LF2, Duplex, Alloy 20, Alloy C-22, Monel	1	-
2	End Connector	S.St 316L , C.St A105, C.St A350 LF2, Duplex, Alloy 20, Alloy C-22, Monel	2	1
3	Ball	S.St A276 316 , Duplex, Alloy 20, Alloy C-22, Monel	2	1
4	Stem	Alloy C-22, Monel S.St A276 316, S.St 17-4PH, Duplex, Alloy 20, Alloy C-22, Monel	2	1
5	Seat	PTFE, RPTFE, TFM, NRG, PEEK, DELRIN	4	2
6	Body Seal	PTFE, Graphite, Impregnated Graphite	2	1
7	Stem Thrust Seal	25% Carbon Filled PTFE, RPTFE, Seal	2	1
8	Body Bolts	TFM, PEEK, NYLATRON	8	-
9	Body Bolts	Stainless Steel ISO 4014 A2-70	-	4
10	Nuts	Stainless Steel ISO 4014 A2-70 (Hex)	-	4
11	Stop Pin		2	1
12	Stem Packing	S.St ASTM A582 303	2	1
13	Follower	PTFE, RPTFE, TFM, Graphite, Impregnated Graphite	2	1
14	Stem Nut	S.St. ASTM B783 316L	4-6	2-3
15	Disc Spring	S.St. ASTM A194 316	4	2
16	Locking Clip	S.St. ASTM A693 17-4PH	2	1
17	Handle	S.St. ASTM A164 304	-	1
18	Sleeve	S.St. ASTM A240 430	-	1
19	Washer	Vinyl Plastisol	-	1
20	Stop Plate	S.St. ASTM A194 316	2	-
21	Wrench Handle	S.St. ASTM A240 430	2	-
22	Wrench Holder	S.St. ASTM A240 430	2	-
23	Wrench Bolt	ASTM A675 Gr.50 Zinc Plated A193 B8M	2	-
24	Body Plug (Insert)	S.St 316L , C.St A105, C.St A350 LF2, Duplex, Alloy 20, Alloy C-22, Monel	-	1

